



New Drawer 16

PRODUCT INFORMATION No. 04-2016

Benedetta Rinaldi

Indel Webasto Marine
Sales & Marketing

-
- ✓ Indel Webasto Marine, first company to introduce the drawer refrigerator concept on the market, has the pleasure to present a new product characterized by ultra compact dimensions, called Drawer 16
 - ✓ The standard door finishing will be stainless steel silver painted and the design will have the same features of the Cruise Elegance line in order to grant the total consistency within the range
 - ✓ Modular in use: it will work as a fridge OR as a freezer

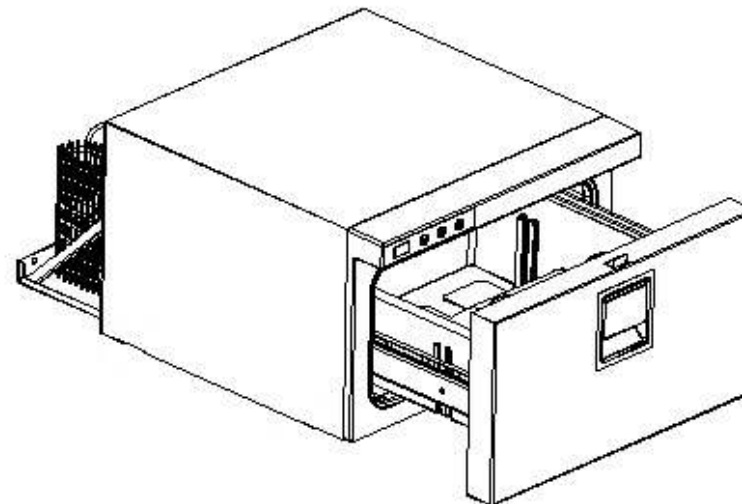
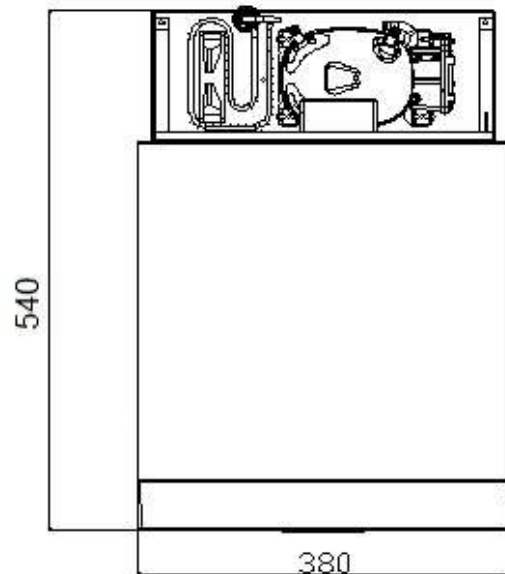
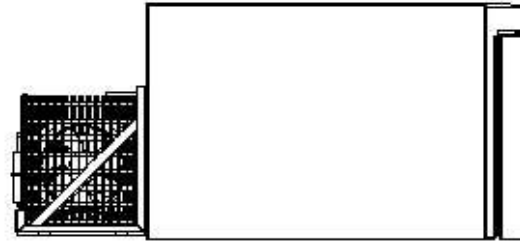
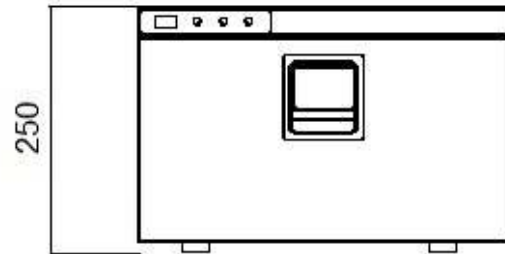

Three-Dimension View of Drawer 16





Features and Benefits

- Real DRAWER concept, not just a sliding bin but a real drawer unit with rails in AISI 304
- New BD Micro compressor installed power, to maximize efficiency and minimize installation space (it will be the first in the market to use that technology)
- Compressor is mounted on a specific new "L" bracket on the back of the fridge. For qualified personnel, it is feasible to mount it in 3 other positions: right, left, top handling the compressor group and especially the piping very carefully to avoid damages. We recommend that this shall be done only by shipyards or bodybuilders and only after being taught thoroughly by our team.

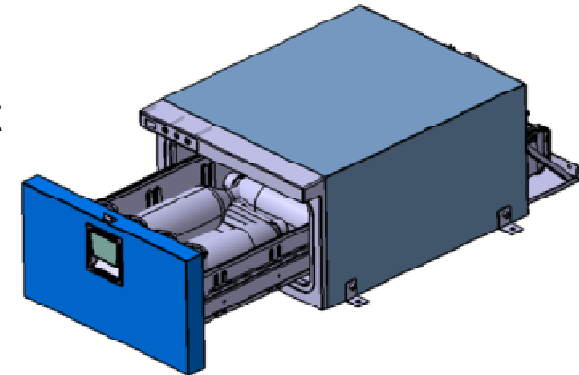

Features and Benefits: Digital Display

- Three digits digital display characterized by the high brightness that makes possible the selection of negative and positive temperatures by the final customer, who is able to choose the intended use of the product (fridge / freezer)
- Splash-proof IPX5 front protection with built in installations
- Temperature range: -6° C to + 10°C



Features and Benefits

- Easy fix system to easier the device installation even without a mounting frame: fridge installation from the interior
- The external flange becomes a design accessory, not needed for installation
- Proper bushing structure prevents insulation's crushing

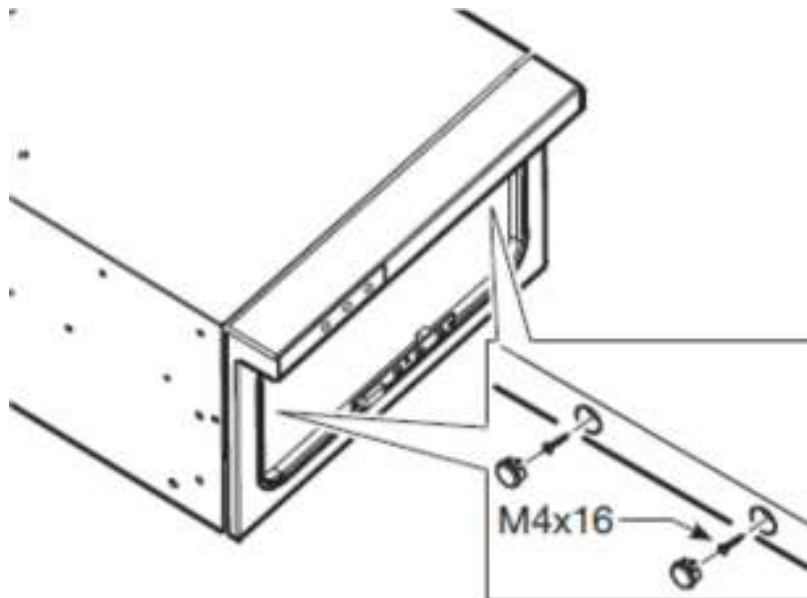

Features and Benefits

- Alternatively, 4 fixing brackets (part of BOM), to allow multiple installation options in critical applications

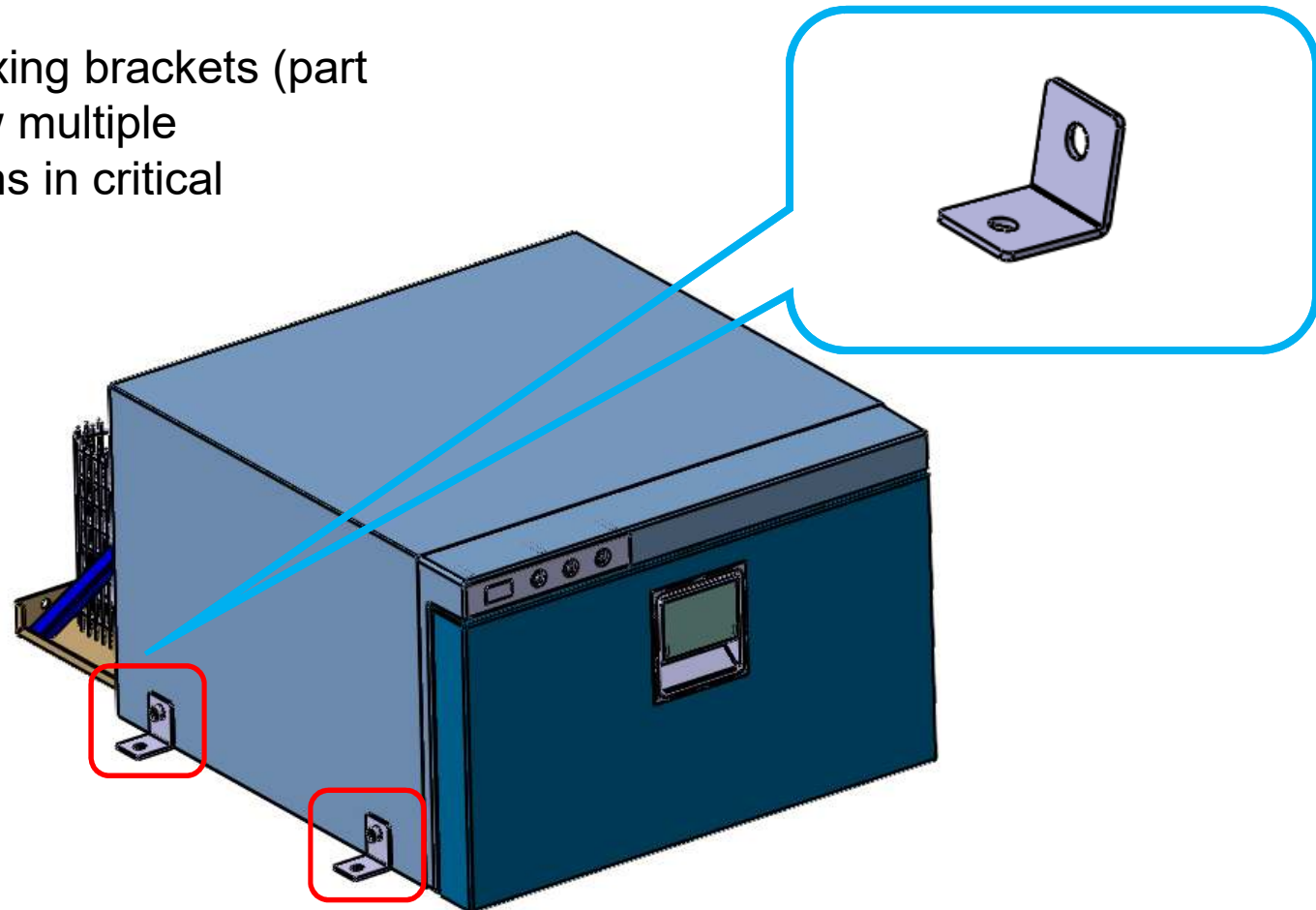

Features and Benefits

- Door in stainless steel AISI 304 silver painted, sliding guides in stainless steel AISI 304. Delivered as standard without fixing frame (easy fix look)
- 3 side shiny stainless steel flush mounting frame as optional
- 4 sides flush flange look (lower side frame available as optional)

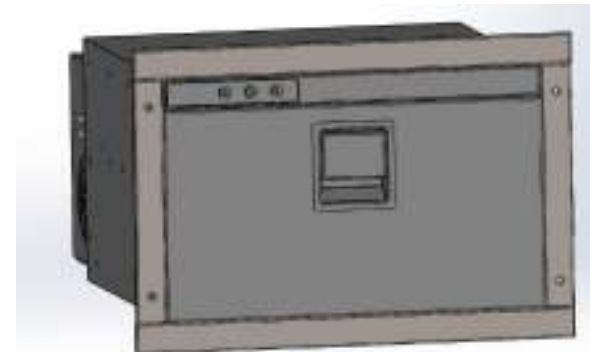



Features and Benefits

- Equipped with SECOP BD 1.4F-FSD 12/24V fixed speed compressor, the smallest and lightest DC unit on the market. Specially designed for **maximum efficiency** and **reliability** and minimize installation space
- Compressor mounted on a specific new «L» bracket on the back of the fridge
- Feasible to remote compressor



Model	DRAWER 16
Effective Volume (L)	16L
Product Dimensions	H250*W380*D540mm
	Depth with remote compressor 395 mm
Net Weight (kg)	12,6
Effective Stroke	200mm
Climatic Class	ST
Compressor Parts	BD1.4F-FSD /101N2500
Rated Voltage/Frequency	DC 12V/24V
Rated Power Input	45W
Power Consumption(kW·h/24h) at 25° C	0.25KWh/24h
Temp. Control	Digital display
Refrigerating Fluid	R134a (22g)
Cooling Mode	Single Cycle Direct Cooling
Evaporator	Plate Evaporator
Condenser	Wire Condenser
Refrigeration Performance in climatic class ST	-6°C~+10° C

Part Numbers, Description, Prices and Availability

Part Number	Description	Price
D016DSAAS12111AA	Drawer 16 DC 12-24V Silver door	PLS contact IWM

Electronic Control Wiring Schematic Diagram

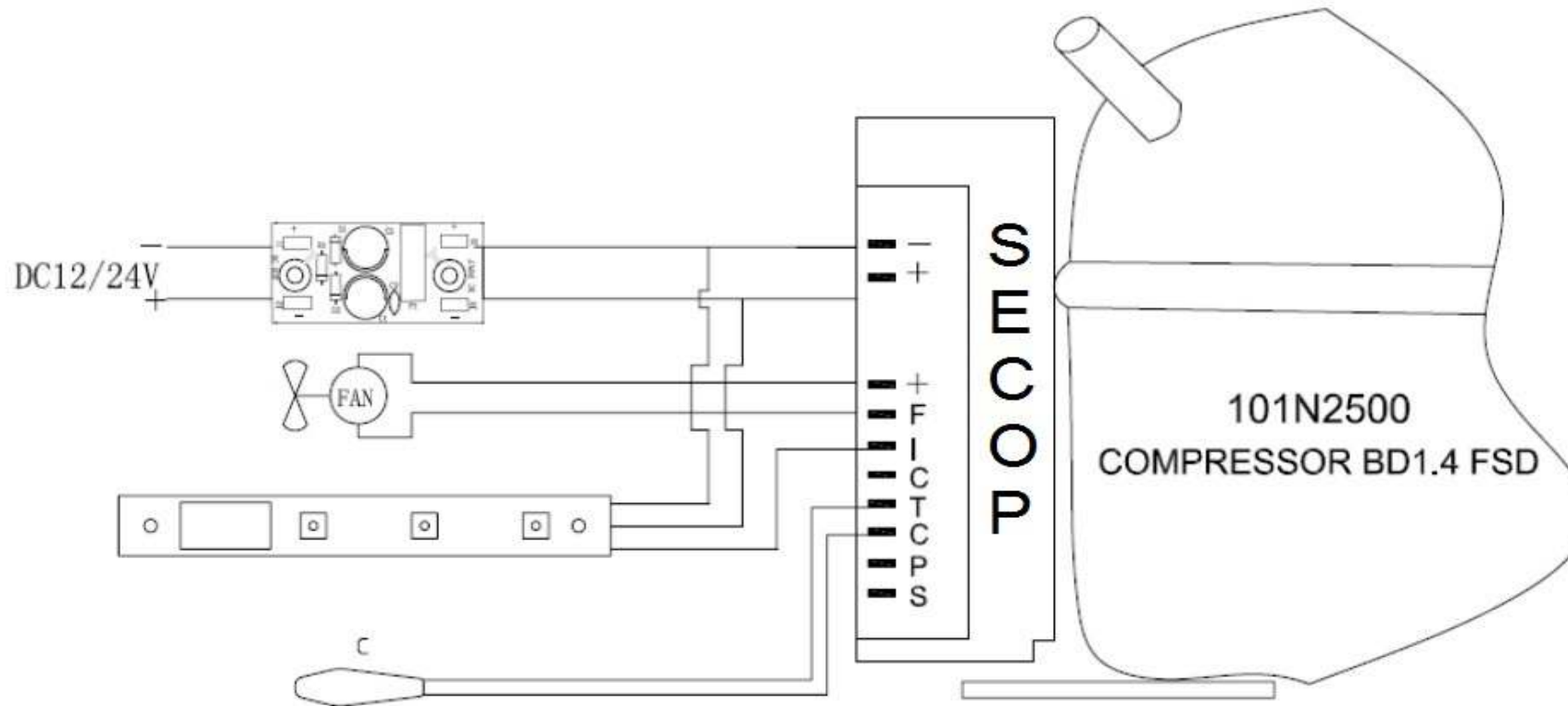

Part Numbers, Description, Prices and Availability

- Indel Webasto Marine Drawer 16 is produced in China and must be ordered from the warehouse in Sant'Agata Feltria, Italy
- It will be in stock starting from October 2016
- No minimum order quantity is requested
- Delivery time is usually 4 weeks from order; minimum stock-in-trade always available for emergencies

Certificates, Documentation, Packaging Details, Maintenance and servicing

- Indel Webasto Marine Drawer 16 is provided with CE certification and E-mark
- Instruction and user manual is included in the packing



Best balance quality/price ratio in its category



Easy to use digital display

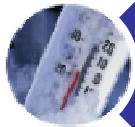

Fridge or freezer function



Practical drawer mechanism, stainless steel guides



Secop BD Micro technology



Multiple installation features



The lightest & smallest fridge/freezer unit on the market !

Thank you for your attention