

attwood®

Sahara-Powered Shower Sump System

4141, 4143, 4144 Series

Installation Instructions

SAVE THESE INSTRUCTIONS

Form Number 69392 Rev. C

03-10

WARNING

Read all instructions carefully before installing and using this product. To prevent personal injury, disconnect the power source when installing or servicing this product. Always remove the boat from the water before using 120V AC power tools.

The Attwood Shower Sump is an efficient, low cost discharge system using an Attwood Sahara Automatic Pump. The sump is designed to transfer "gray" water from the shower and other water drains. Multiple inlets can be attached to more than one drain, with different hose sizes. The see-through top on the box allows visual inspection of the filter.

Refer to this chart to be sure you have selected the proper sump for your application:

Performance Specifications

12-Volt Models			ABYC Specifications @13.6 VDC (GPH = Gal. Per Hour)			ISO Specifications @12.0 VDC (LPH = Liters Per Hour)		
Part Num.	Series	Amp Fuse	0 ft. Head GPH/ amps	3.3 ft. Head GPH/ amps	6.7 ft. Head GPH/ amps	0kPa Head LPH/ amps	10kPa Head LPH/ amps	Max Head (ft. @13.6v) kPa @12v
4141	500	2A	420/1.6	360/1.5	215/1.5	1460/1.2	1100/1.2	9'3"/21 Pa
4143	750	4A	650/2.5	500/2.4	385/2.4	2160/2.5	1592/ 2.4	13'/33 kPa

24-Volt Models			ABYC Specifications @27.2 VDC (GPH = Gal. Per Hour)			ISO Specifications @24 VDC (LPH = Liters Per Hour)		
Part Num.	Series	Amp Fuse	0 ft. Head GPH/ amps	3.3 ft. Head GPH/ amps	6.7 ft. Head GPH/ amps	0kPa Head LPH/ amps	10kPa Head LPH/ amps	Max Head (ft. @24v) kPa @24v
4144	750	2A	650/1.4	500/1.4	385/1.4	2217/1.2	1668/1.2	13'/33 kPa

REQUIRED FOR INSTALLATION

- Fine-tooth hacksaw or band saw
- File
- Cordless drill and suitable drill bits
- Four #8 stainless steel Phillips pan-head fasteners for slotted mounting feet
- One clamp (#9185) for each hose used
- 16-gauge wire and waterproof crimp connectors
- Fuse holder (Attwood #14341) and suitable fuse (see chart above)

Optional

- Switch (Attwood #7615 or equiv.) to allow shut-off in emergency

Required if no sump pump mounting pad is in place:

- 1/2" (13mm) thick marine plywood block large enough to mount sump pump
- Hand-held roller
- Fiberglass-18 oz. mat or woven roving
- Polyester resin and catalyst

INSTALLATION LOCATION

1. Sump must be lower than shower and all other drains. (Figure 1)
2. For correct operation of the automatic float switch, sump box must be mounted level.

3. Because sailboats tend to heel, place sailboat sump installations close to the centerline and parallel with the bow-to-stern line. Outlet end can face either fore or aft.
4. Before drilling, be sure there is enough side room for inlet/outlet hoses, and maintain enough overhead clearance to remove and reinstall box.
5. For confined areas, mount box so the lid tabs are accessible on at least one side.

Figure 1

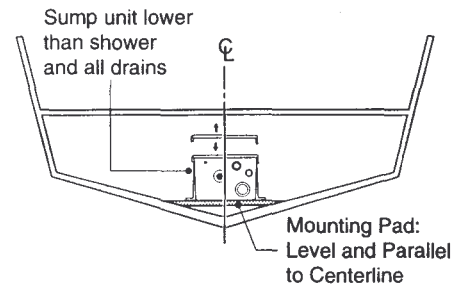

TO INSTALL MOUNTING PAD (If Required)

1. Locate mounting pad (marine plywood) in proper position. (Figure 1)
2. Sand gelcoat or paint off mounting surface to prepare an area 3" (8cm) wider than the mounting pad on each side.
3. Completely cover the mounting pad with fiberglass. Saturate fiberglass with resin, and press the fiberglass edges down against the hull to adhere pad in place. Roll out the fiberglass to remove uneven surfaces, air bubbles, or excess resin.

SUMP INSTALLATION INSTRUCTIONS

1. To open lid, release the tabs on one side of box. Rotate lid up and lift from box.
To replace: Carefully seat lid gasket onto box edges. Press down until all tabs snap into place.
2. For multiple inlets/hose sizes, determine opening sizes needed and saw ends off the correct fittings. Sizes and cut locations are marked on the fittings. File around outside and inside of the fittings to remove burrs and rough edges. (Figure 2)

Figure 2

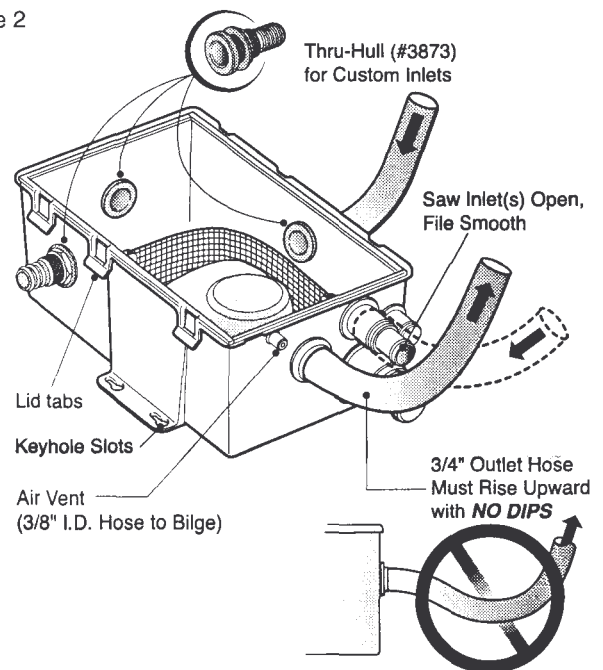

3. Custom inlet locations must be within filtered area. Choose a suitable thru-hull connector (Attwood #3873 or equiv.), drill hole in sump box, and install thru-hull with non-silicone marine sealant.

CAUTION

Before drilling for mounting feet, be sure pilot holes and fasteners will not pierce hull. A mounting pad is recommended. (Figure 1)

- Place sump box in final position. Mark narrow end of each keyhole screw slot. Remove box and carefully drill four 1/8" (3mm) pilot holes.
- Replace box and fasten with four #8 stainless steel Phillips pan-head fasteners.
- Connect 3/4" (19mm) I.D. hose from outlet fitting to the thru-hull connector. Secure each connection with hose clamp.

IMPORTANT: Route outlet hose so it rises smoothly from the sump, up to the thru-hull. Support hose if necessary. Any downward dip will create air lock and prevent pump operation.

IMPORTANT: Inlet hoses must rise smoothly from the fittings, up to their drains.

- Connect inlet hoses from drains to the inlet fittings. Secure each connection with a hose clamp.
- Connect 1/4" (6mm) I.D. tubing from air vent to the bilge to allow overflow.

WIRING INSTRUCTIONS

⚠ WARNING

Models 4141 and 4143: Use 12-volt DC power source only.

Model 4144: Use 24-volt DC power source only. Incorrect DC voltage or use of AC voltage may cause serious damage and/or personal injury. Circuit must be properly fused to prevent possible fire hazard and/or damage to pump and switch if the pump becomes jammed.

CAUTION

Make all connections using waterproof crimp-on connectors for 16-gauge wire.

- Connect wiring as shown in Figure 3.

Figure 3

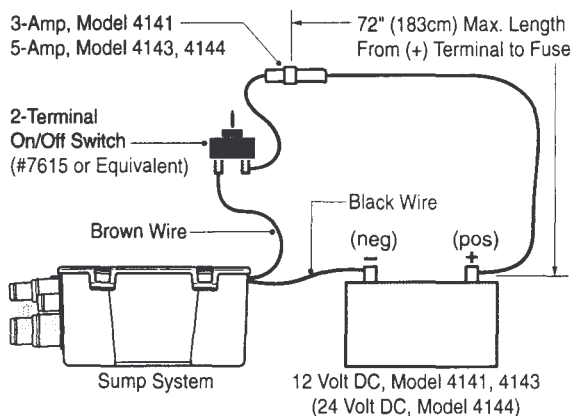

- Splice fuse holder into positive lead (brown) at a location easily accessible for changing fuses. Fuse must not be more than 72" (183cm) from the battery. Install the specified fuse.
- Connect brown wire from sump system to the fused positive (+) power source. If using manual on/off switch (Attwood #7615 or equivalent) connect brown wire from sump system to the switch, then to the fused positive (+) power source.
- Connect black wire from the sump system to the negative (-) battery terminal.
- Test unit for proper installation. Feed water into the sump; if the outlet flow appears to be too low, check wire connections.

IMPORTANT: Reversed connections will cause opposite pump rotation, which drastically reduces capacity and can cause premature pump failure.

MAINTENANCE INSTRUCTIONS

Drain the sump system during cold weather and when not in use:

- Disconnect and drain all lines to the unit.
- Loosen hold-down screws, remove and empty the sump system.
- In some installations, it may be impossible to completely drain the system. Add a non-toxic RV/marine antifreeze to the shower drain and circulate it throughout the system.

To Clean Filter for Improved Performance:

- Release lid tabs. Rotate lid up and lift from box. (Figure 4)
- Pull the filter straight up and out of slots. Clean filter, re-install and replace cover.

- To replace Sahara Pump or Check Valve (#911404): From inside of box, pull pump out of outlet grommet. Remove Check Valve from outlet nozzle.
- Replace in reverse order. When replacing pump, seat wires into slots at top of box.

Figure 4

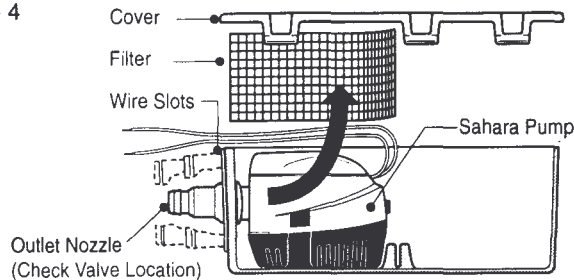

TROUBLE SHOOTING

Problem	Probable Cause
Pump will not turn on	<ul style="list-style-type: none"> Line is plugged Line is broken No power to the pump Fuse is blown System improperly wired Manual switch is not turned on
Pump will not turn off	<ul style="list-style-type: none"> System improperly wired Box not mounted level
Pump output is low	<ul style="list-style-type: none"> System wired backwards Line is plugged/restricted
System is leaking at inlet/outlet connection	<ul style="list-style-type: none"> Hose clamp is missing Hose clamp is loose Pipe connection is loose
Pump turns on but does not pump	<ul style="list-style-type: none"> Line is plugged Outlet hose does not rise continuously to thru-hull
Water returns to sump from outlet hose	<ul style="list-style-type: none"> Check valve plugged or damaged

ATTWOOD LIMITED WARRANTY

ATTWOOD CORPORATION, 1016 North Monroe, Lowell, Michigan 49331 ("Attwood") warrants to the original consumer purchaser that Attwood brand products will be free from defects in materials and workmanship under normal use and service for one year from the date of original consumer purchases. This limited warranty is not applicable if the product has been damaged by accident, improper installation, unreasonable or improper use, lack of proper maintenance, unauthorized repairs or modifications, normal wear and tear, or other causes not arising out of defects in materials or workmanship. Attwood products are warranted for use on pleasure boats. Any other use — including but not limited to commercial, racing, or non-marine use — are not covered under this warranty. Attwood's obligation under this warranty is limited to repair of the product at Attwood's plant or replacement of the products at Attwood's option without expense to the original consumer purchaser. Any expenses involved in the removal, reinstallation or transportation of the product are not covered by this warranty. The product must be returned to Attwood's plant at the address above, postage prepaid, and insured with proof of original purchase including date. If Attwood is unable to replace the product and repair is not commercially practical or cannot be timely made, or if the original consumer purchaser is willing to accept a refund in lieu of repair or replacement, Attwood may refund the purchase price, less an amount for depreciation. The acceptance by Attwood of any product returned or any refund provided by Attwood shall not be deemed an admission that the product is defective or in violation of any warranty. Products that are replaced or for which a refund is issued become the property of Attwood.

THIS WARRANTY IS ATTWOOD'S ONLY EXPRESS WARRANTY OF THIS PRODUCT. NO IMPLIED WARRANTY SHALL EXTEND BEYOND ONE (1) YEAR FROM THE DATE OF ORIGINAL CONSUMER PURCHASE. ATTWOOD SHALL NOT BE LIABLE FOR ANY DAMAGES FOR LOSS OF USE OF THIS PRODUCT, NOR FOR ANY OTHER INCIDENTAL OR CONSEQUENTIAL DAMAGES, COSTS OR EXPENSES.

Some states do not allow limitations on how long an implied warranty lasts or the exclusion or limitation of incidental or consequential damages, so the above limitations and exclusions may not apply to you. This warranty gives you specific legal rights, and you may have other rights which vary from state to state.